

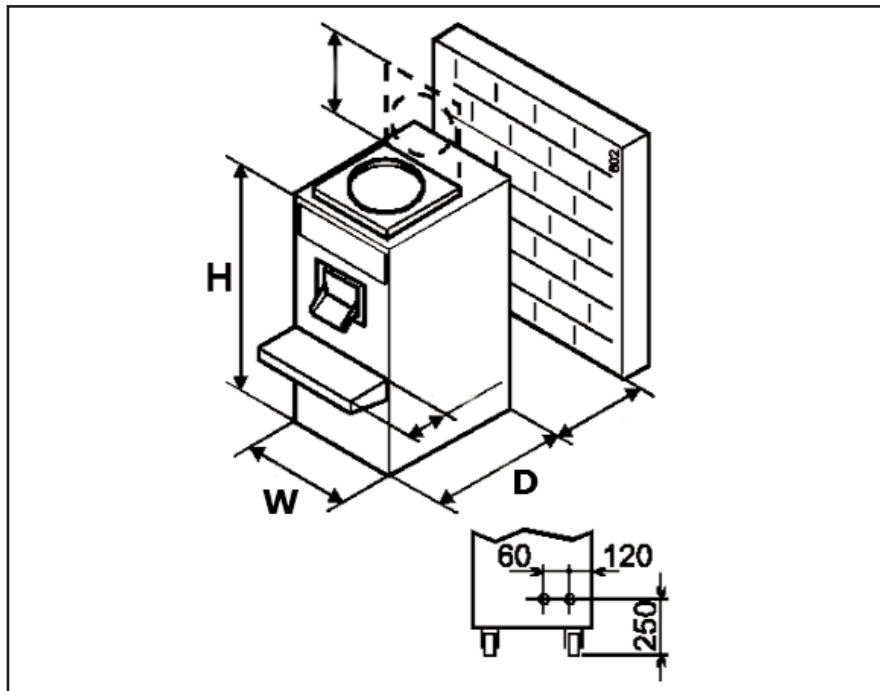

- Two parallel refrigeration systems reduce energy and water consumption.
- Vertically oriented freezing cylinder provides high capacity, and maximum energy efficiency.
- Large diameter freezing cylinder facilitates extremely fast freezing times, resulting in very small ice crystal formation.
- Easy cleaning and simple assembly of beater parts.
- Low cost, long wearing, NSF approved plastic beater blades minimize frequent and costly blade replacement.
- Heavy-duty stainless steel beater shaft built to withstand years of use.
- Clear acrylic freezing cylinder cover allows monitoring of product while freezing.
- Easy access to freezing cylinder when adding variegates and particulates.
- Provides thorough mixing of variegates and particulates unachievable with horizontal barrels.
- All controls and indicators conveniently grouped in a single panel, on the front of the freezer.
- All buttons and indicators identified by easily understood symbols relative to their function.
- Time/temperature controlled freezing achieves same smooth texture and product consistency across full and partial batches, a feature not possible with consistency controlled freezers.
- Swing gate style, stainless steel extraction door design provides rapid extraction of product.
- Two robust 5.0 horsepower, semi-hermetic compressors, engineered for high quality and outstanding reliability.





VB120		
Dimensions	Machine	with crate
width	21-3/4" (55,2 cm)	24" (61,0 cm)
height	47-1/4" (120,0 cm)	62-1/4" (158,1 cm)
depth	30-3/4" (78,1 cm)	34-1/2" (87,6 cm)
Weight	814 lbs (369,2 kg)	864 lbs (391,9 kg)
Electrical	<b>3 Phase, 208-230 VAC, 60Hz</b>	
running amps	approximately 48A	
fuse size	60A maximum	
breaker type	HACR or regular	
Compressor	Two - 5 hp semi-hermetic	
Drive Motor	9.1 hp	
Air Flow	Water cooled units require 3/4" N.P.T. water and drain fittings.	
Cylinder Capacity	11.25 gallon (42,60 liters)	
Liquid Mix Per Batch	5-19 quarts	
Working Cycle	5-12 minutes	
Warranty	Two-year warranty on freezing cylinder, compressor, drive motor, gearbox, and agitator shaft. One-year warranty on remaining parts and labor.	

Continuous research leads to ongoing product improvements; therefore, these specifications are subject to change without notice.

Distributed by:



FOODSERVICE EQUIPMENT  
 502 Highway 67 • Kiel, WI 53042-1600  
 920-894-2293 • 800-558-5807  
 Fax: 920-894-7029  
 E-mail: [foodservice@stoelting.com](mailto:foodservice@stoelting.com)  
[www.stoeltingfoodservice.com](http://www.stoeltingfoodservice.com)

ISO 9001:2000 Registered

Certified, Listed and/or Recognized by:

